

3700 EAST MERCER WAY
BARNABIE POINT PROJECT

NO.	DATE	DESCRIPTION
	25 AUGUST 2025	90% CONSTRUCTION DOCUMENTS
PROJECT:		OVERALL MASS EXCAVATION AND TESC PLAN

C2.00



1/20/2024 4:12:30 PM C:\Users\anjali\Documents\BARNABIE POINT_Corridor Plan_Sheet C2.00.rvt
© ANJALI GRANT DESIGN LLC ORIGINAL SHEET SIZE: 22" x 34"

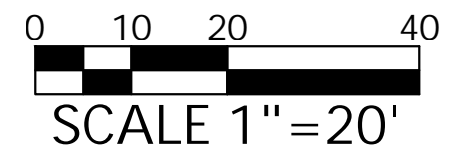

LEGEND

- VEG TREE PROTECTION
- SF SILT FENCE
- INLET PROTECTION

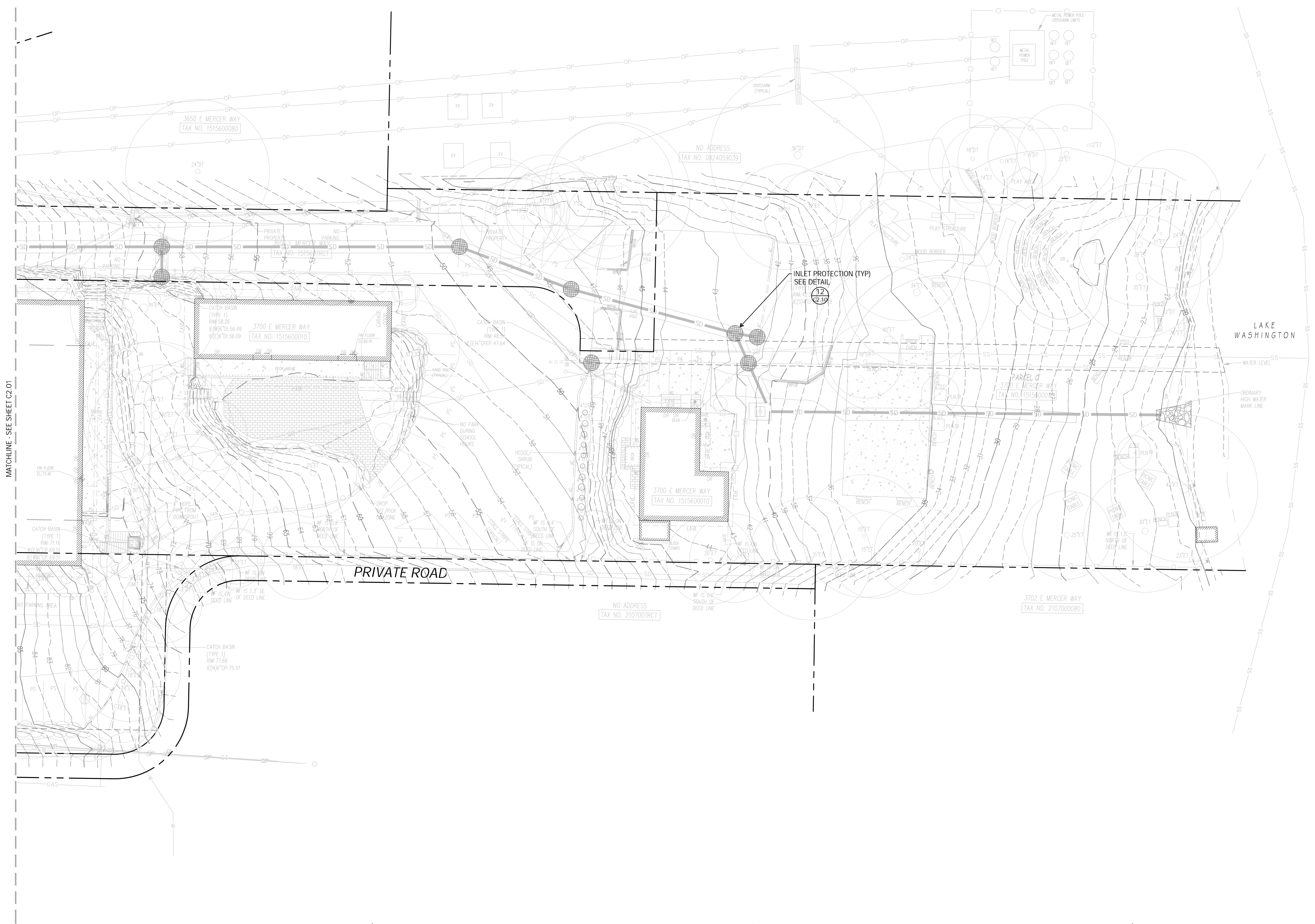

3700 EAST MERCER WAY
 BARNABIE POINT PROJECT

NO.	DATE	DESCRIPTION
	25 AUGUST 2025	90% CONSTRUCTION DOCUMENTS
PROJECT: MASS EXCAVATION AND TESC PLAN		

C2.02



1/10/2025 4:12:30 PM C:\Users\anjali\Documents\BARNABIE POINT\Barnabie Point\Barnabie Point.dwg
 © ANJALI GRANT DESIGN LLC ORIGINAL SHEET SIZE: 22" x 34"

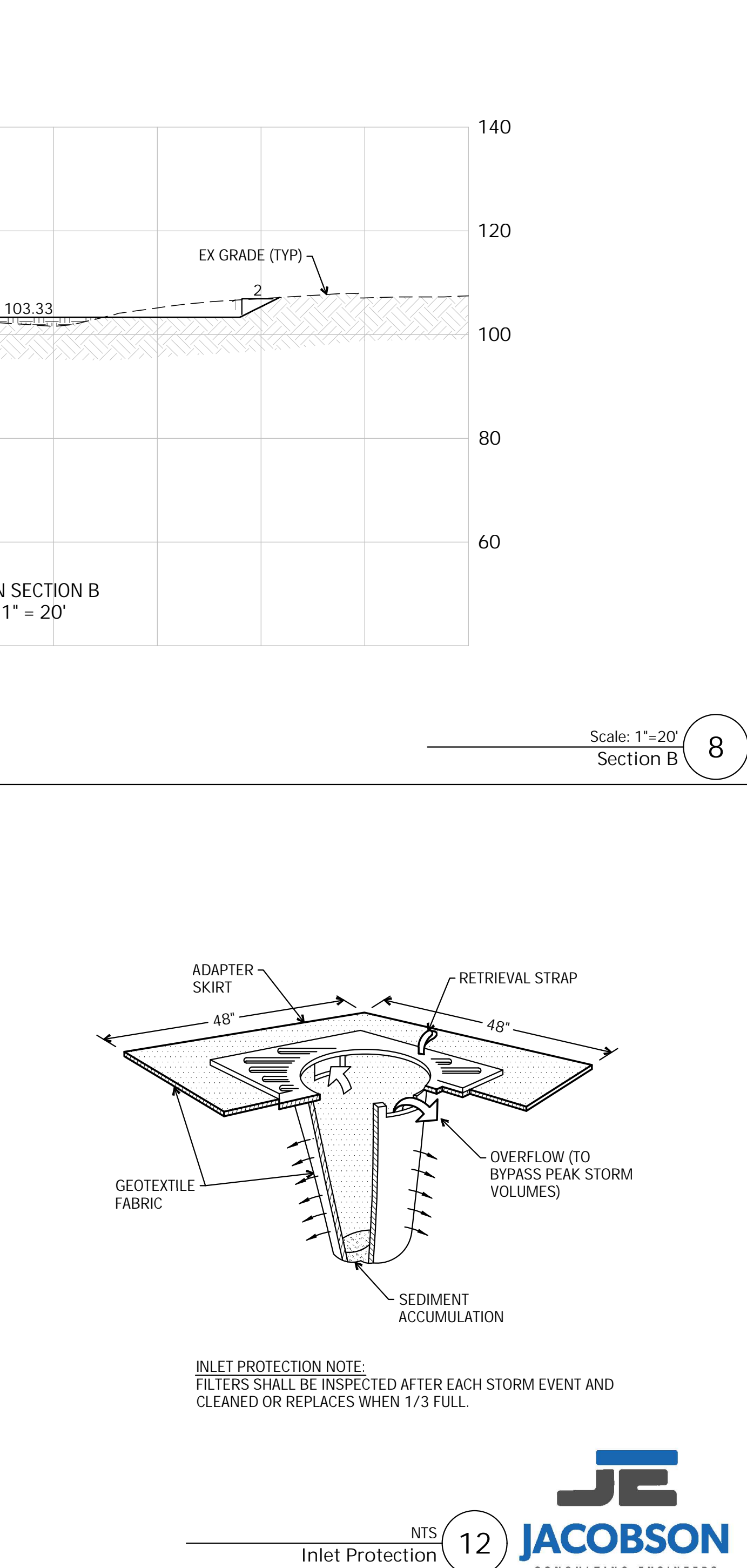
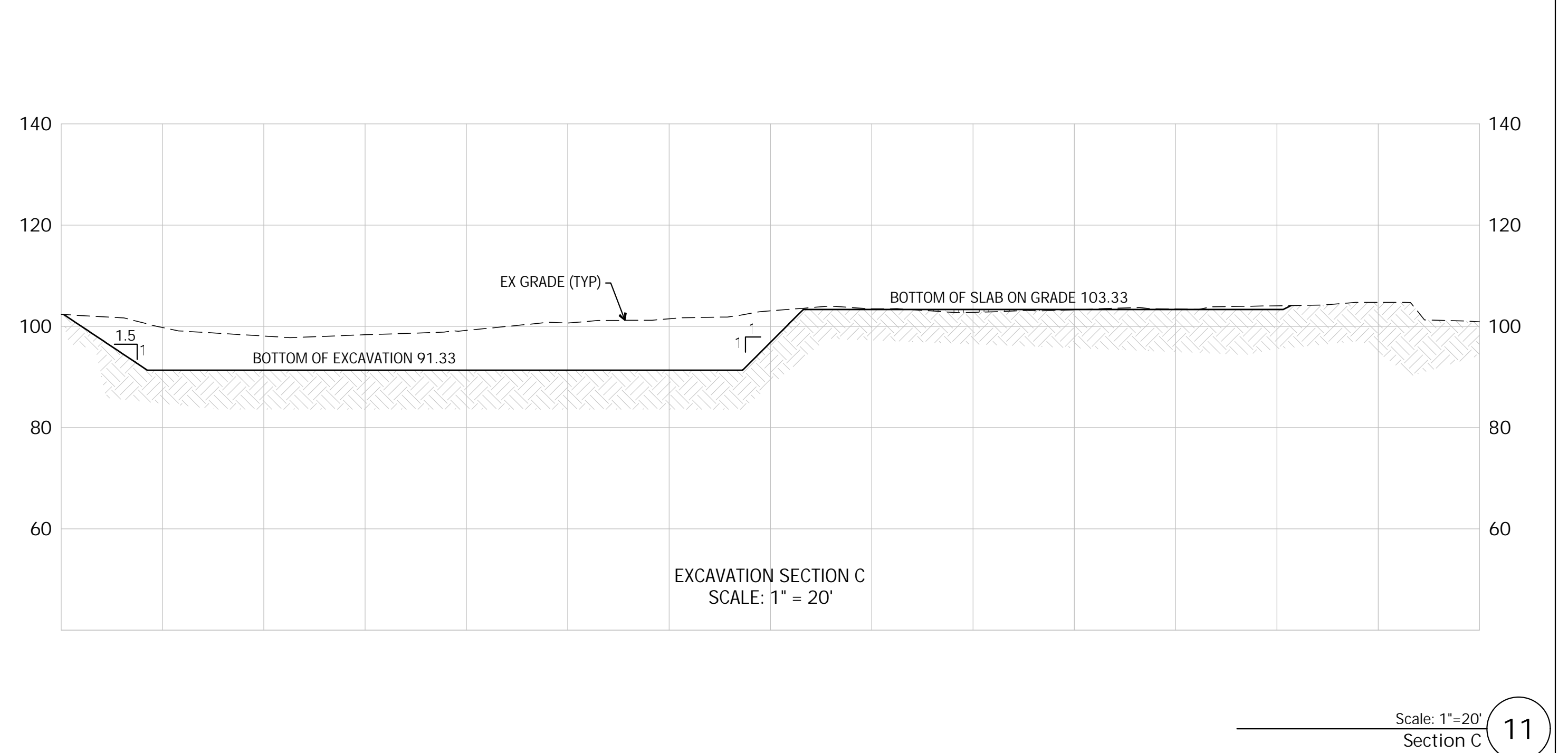
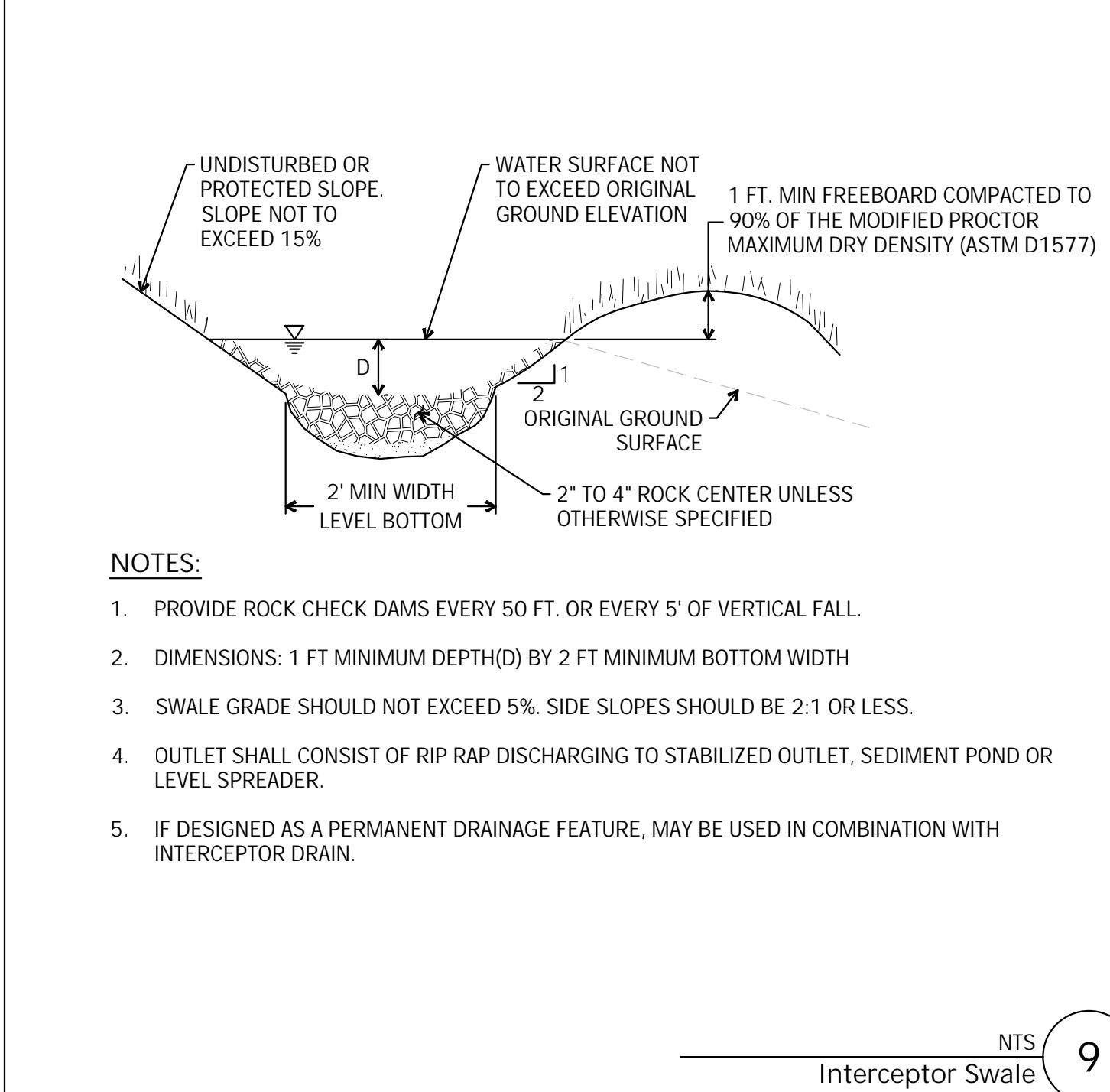
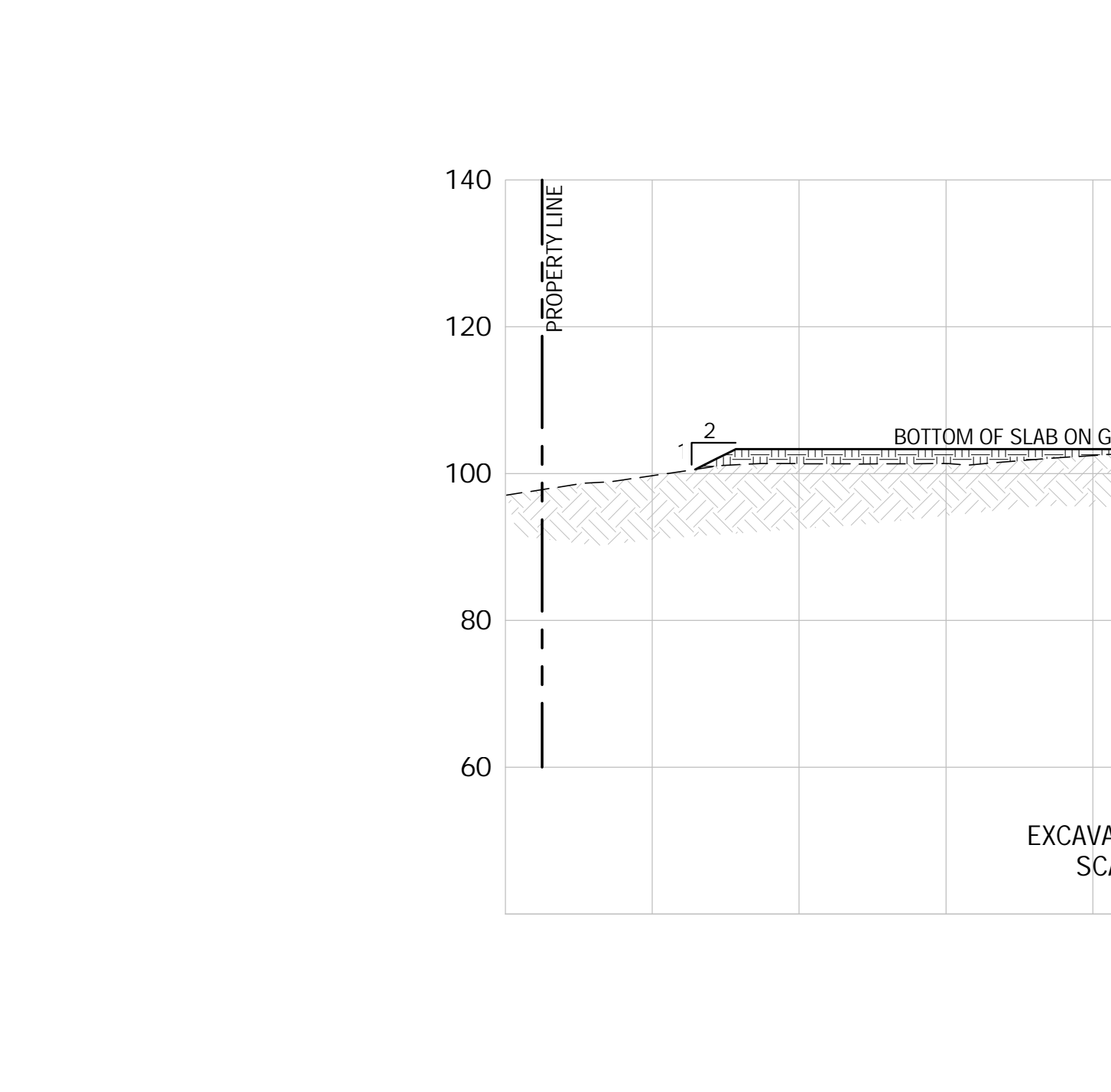
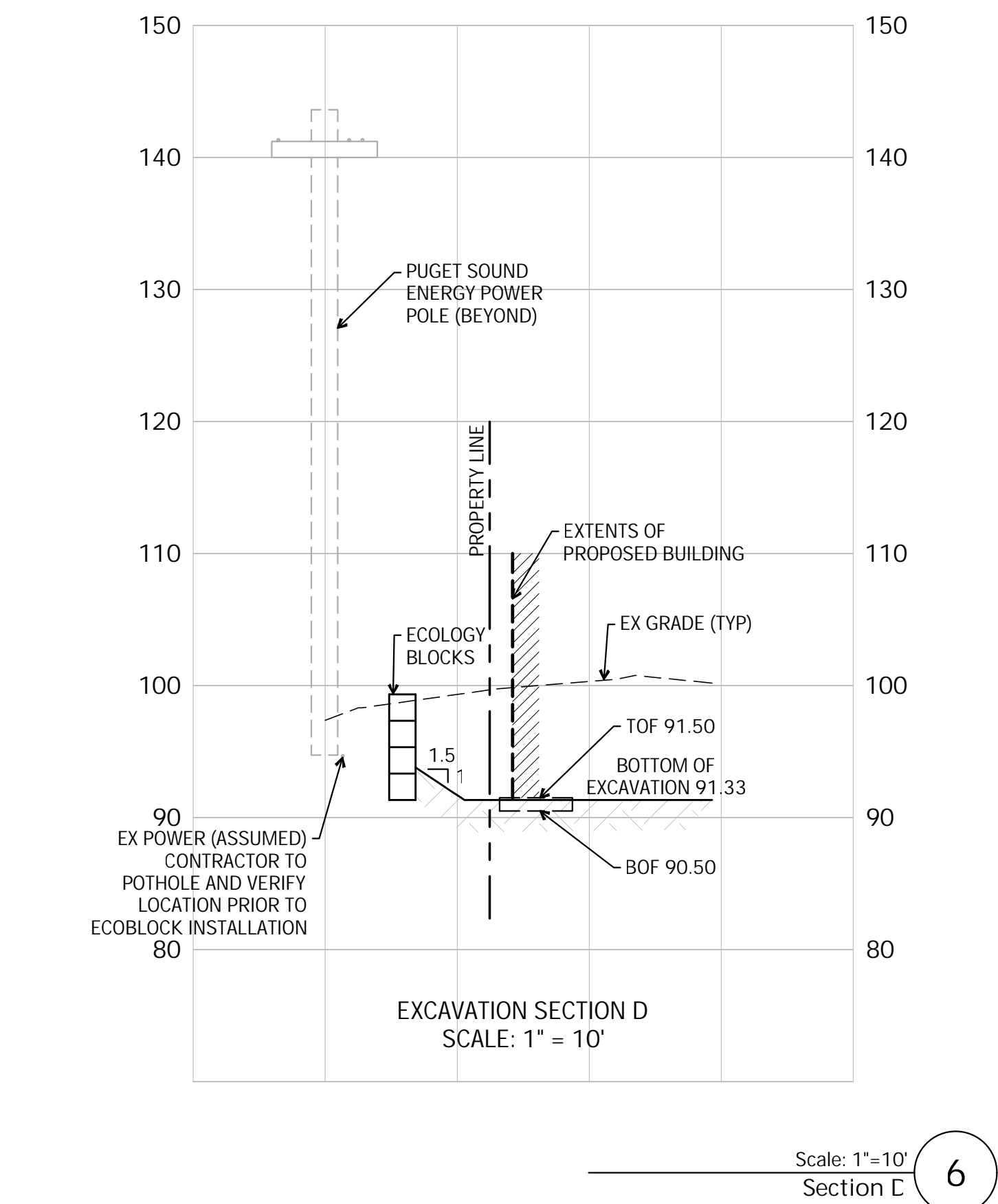
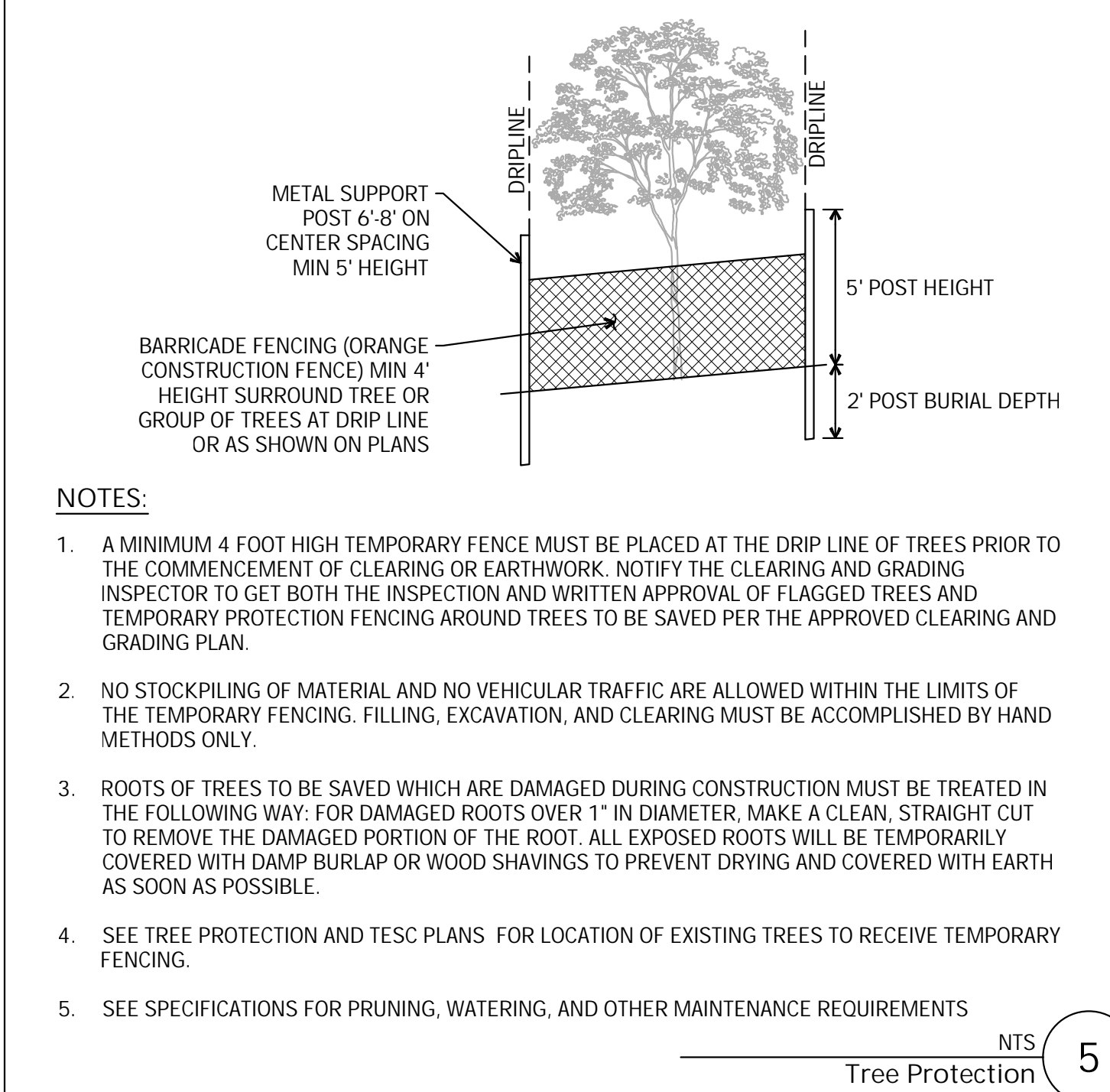
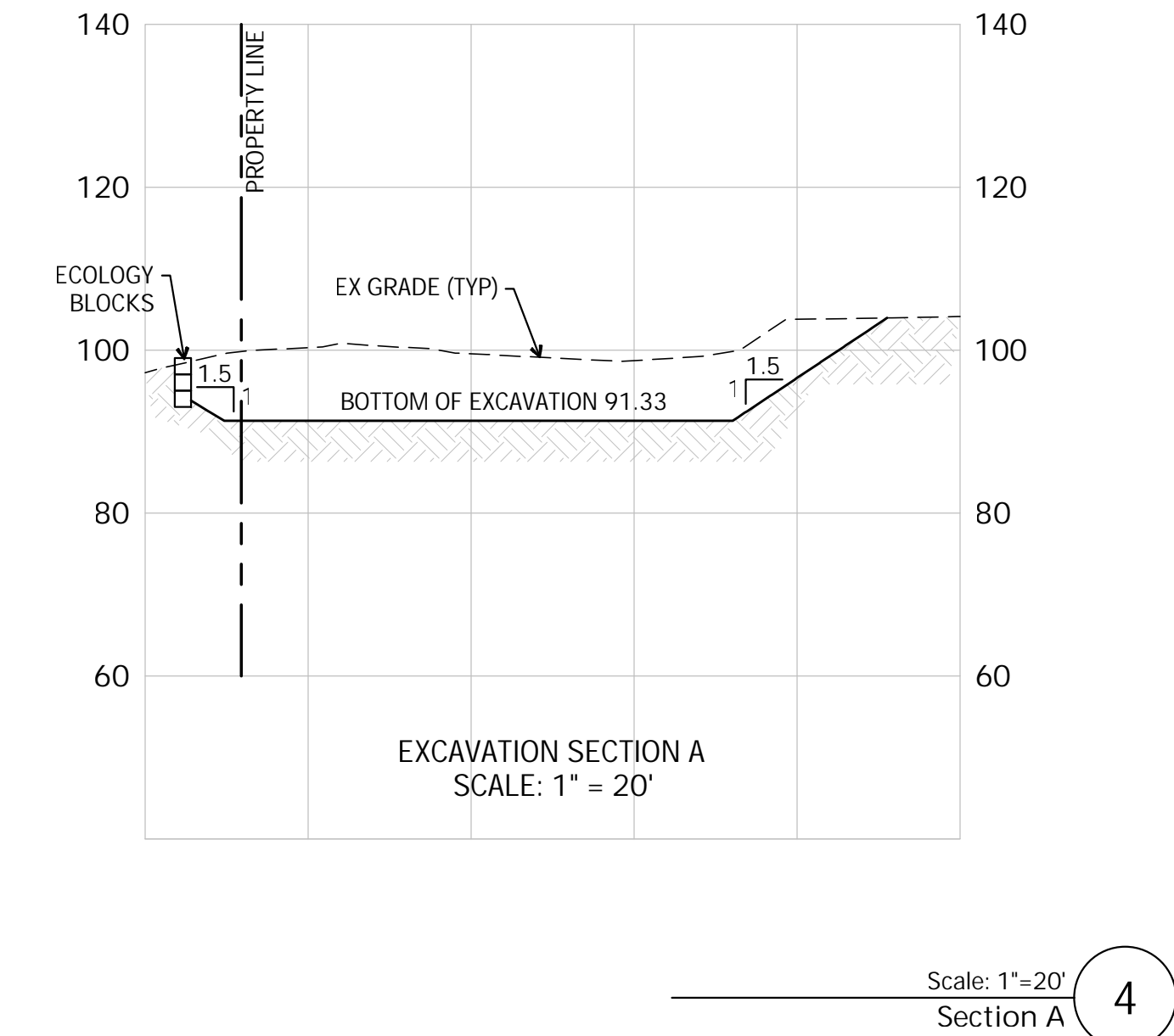
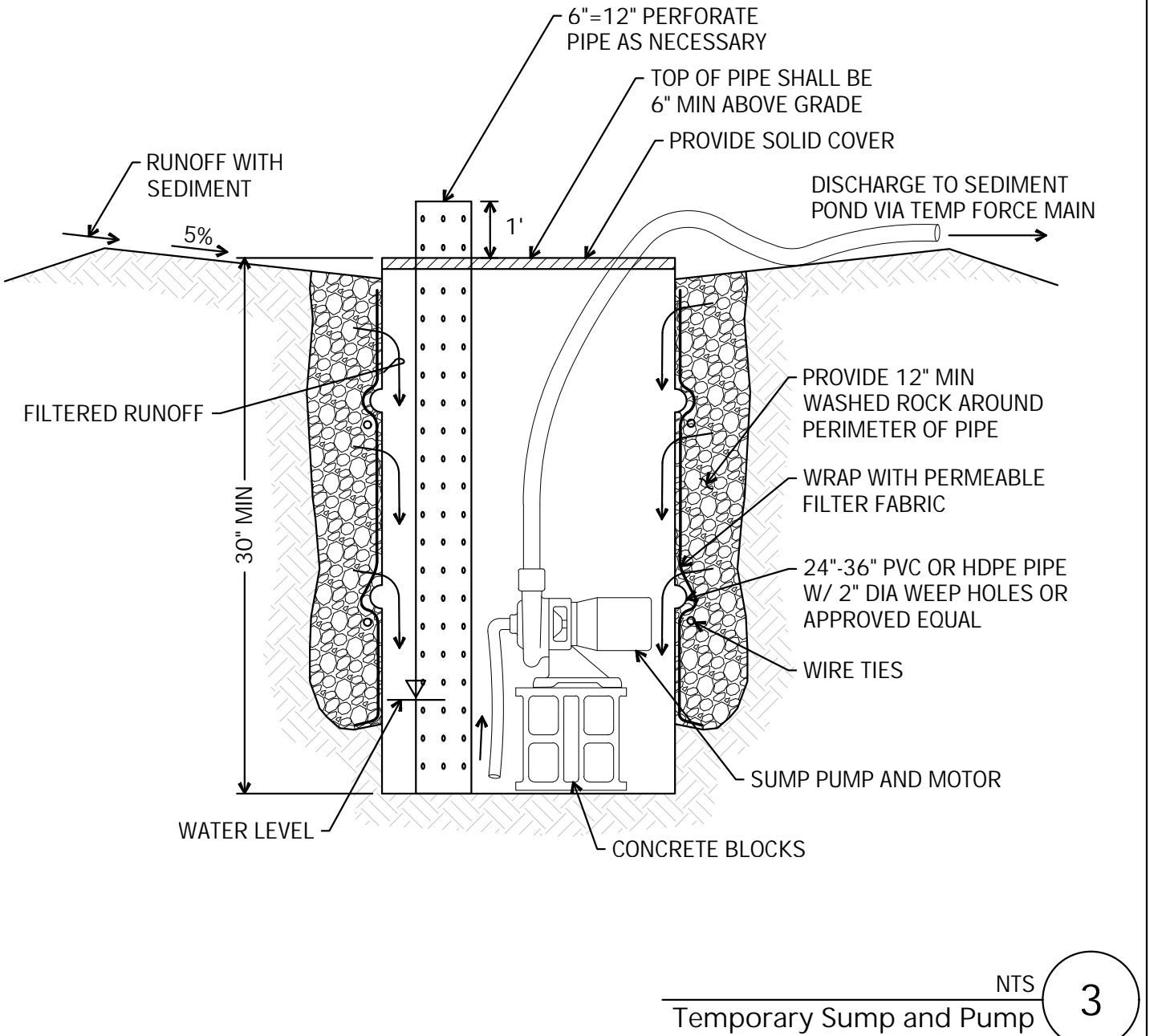
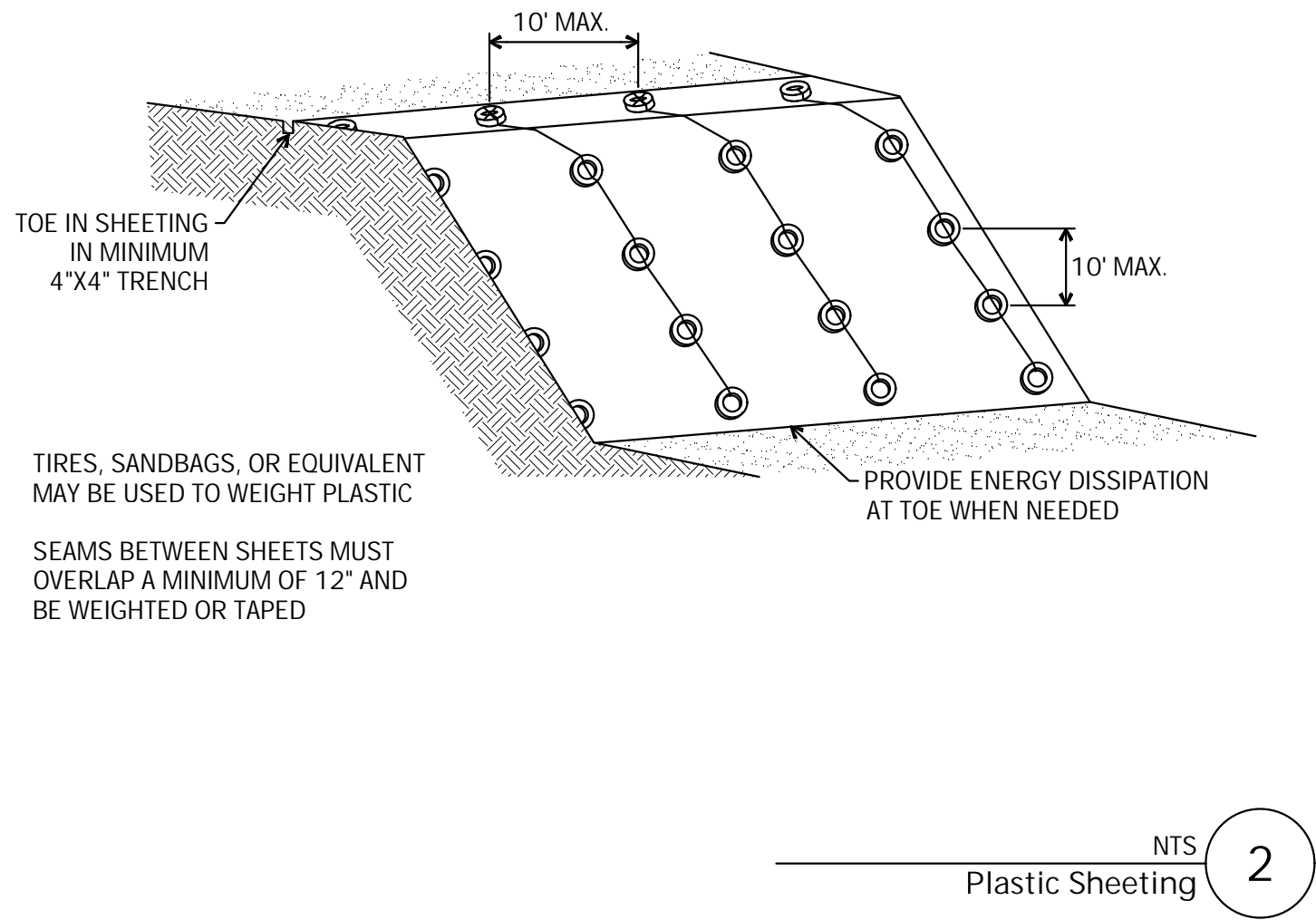
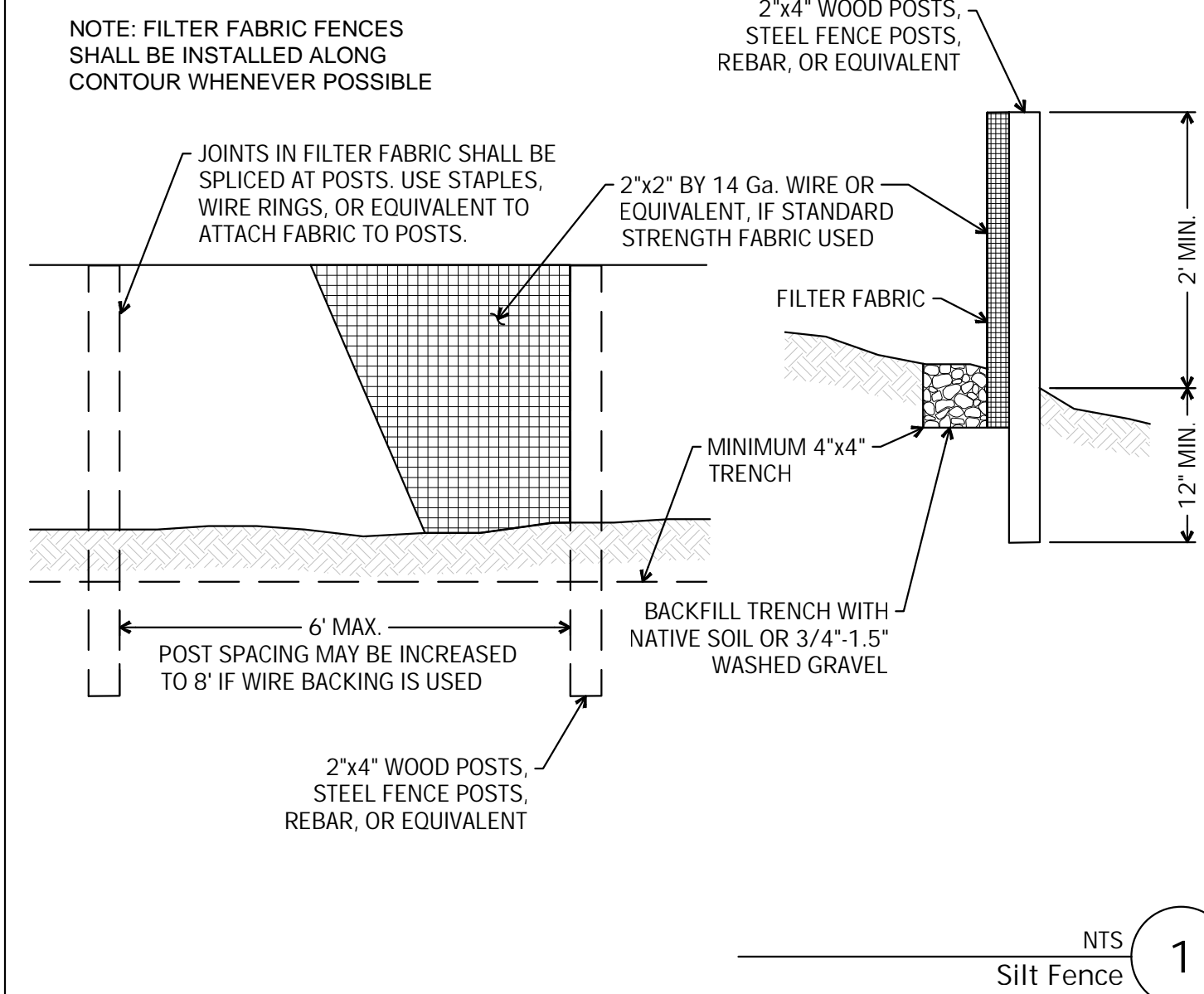

NO.	DATE	DESCRIPTION
	25 AUGUST 2025	90% CONSTRUCTION DOCUMENTS
PROJECT: TESC DETAILS		

C2.10



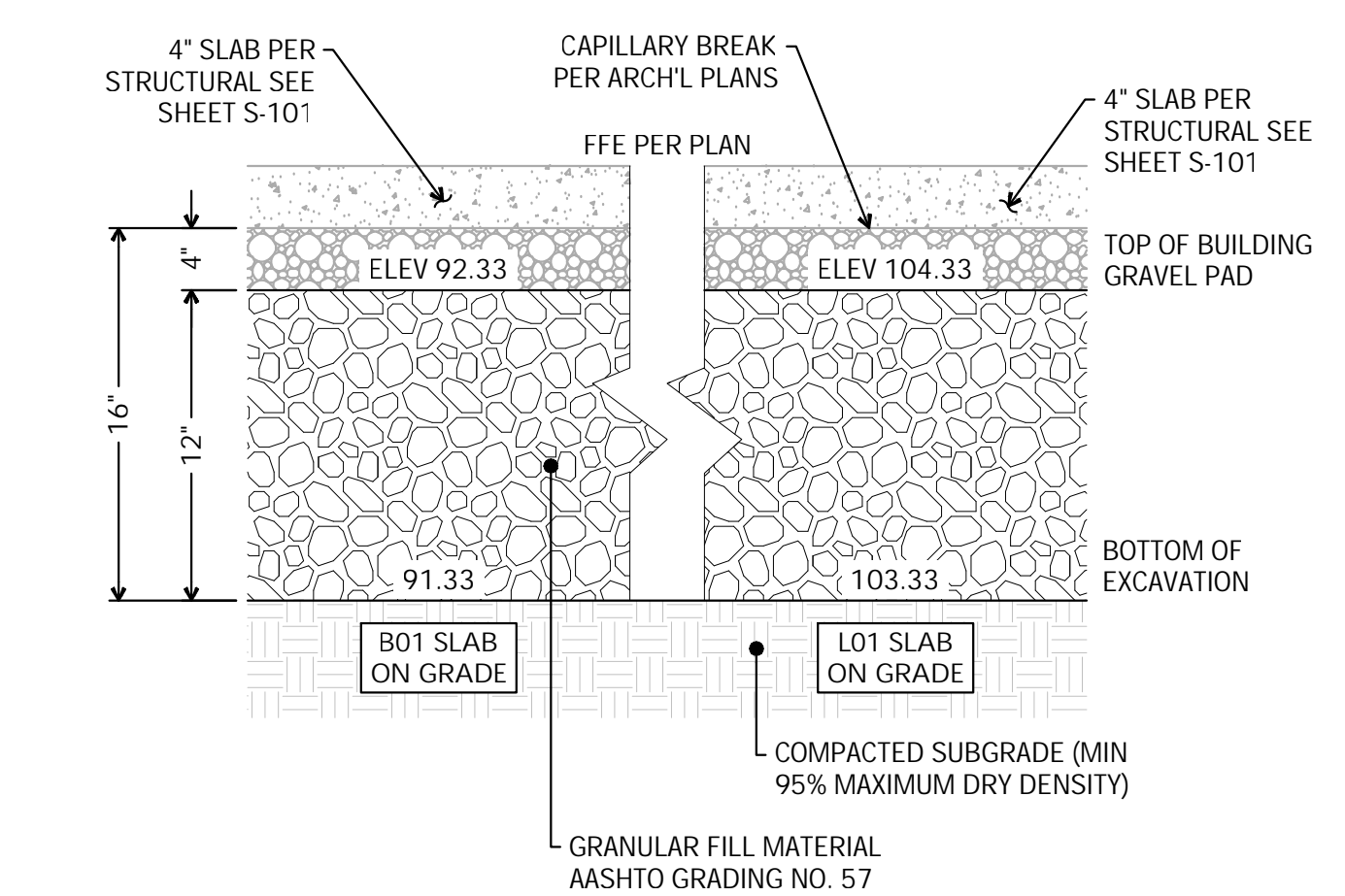
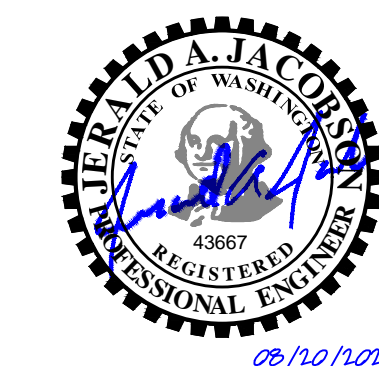

NOTES:

- 1. ALL SURFACES COMPACTED TO 95%

NTS
Not Used 1

NTS
Not Used 2

NTS
Not Used 3

NTS
Gravel Building Pad 4

NTS
Not Used 5

NTS
Not Used 6

NTS
Not Used 7

NTS
Not Used 8

NTS
Not Used 9

NTS
Not Used 10

NTS
Not Used 11



3700 EAST MERCER WAY
BARNABIE POINT PROJECT

NO.	DATE	DESCRIPTION
	25 AUGUST 2025	90% CONSTRUCTION DOCUMENTS
PROJECT:		TESC DETAILS

C2.11